

analytical purposes and also to probe the conformation and configuration of adsorbed molecules and enzymes. The application of enzymes which catalyze reactions to form electroactive products, so that they behave as heterogeneous electrocatalysts, is particularly of interest. The changes in behavior of the adsorbed urease can be attributed to changes in conformation upon reduction and reoxidation. On reduction the disulfide bond oriented at the mercury surface is broken (forming $-SH$ or $-S^-$) and the free movement at this site is sufficient to alter the distant active site and decrease the activity. The sulfhydryl groups do not move far apart, however, since reoxidation causes restoration of at least some of these bonds and thus enzymatic activity. Analogous behavior has been seen previously for enzyme systems. Thus the reversible denaturation of proteins is well-known and it has been shown that proteins (e.g., ribonuclease) containing disulfide bonds which have been ruptured by reductive cleavage in denaturing solvents will refold almost quantitatively upon oxidation to the native state.¹⁴ Similarly the large change in the activity of a bound enzyme upon a small structural perturbation of a distant site has precedence in the work of Berezin et al.¹⁵ These authors found that when trypsin was covalently bound to a nylon filament, the enzymatic activity was greatly decreased upon mechanical extension of the filament. Indeed these authors believe that deformations of the native conformation as small as 0.5 Å are sufficient to cause changes in the catalytic activity. The possibility of varying enzyme behavior by electron transfer at a surface adds an additional degree of control (and also added constraints) to modified electrodes with adsorbed enzymes. The possibility that such control processes are utilized in biological systems bears further investigation.¹⁶

References and Notes

- (1) M. I. Stankovich and A. J. Bard, *J. Electroanal. Chem.* in press.
- (2) M. I. Stankovich, Ph.D. Dissertation, University of Texas at Austin, 1975.
- (3) C. Tanford, *J. Am. Chem. Soc.*, **74**, 6036 (1952).
- (4) K. Mosbach and B. Danielsson, *Biochim. Biophys. Acta*, **364**, 140 (1974).
- (5) O. R. Zaborisky, "Immobilized Enzymes", Chemical Rubber Publishing Company, Cleveland, Ohio, 1973.
- (6) N. Jespersen, *J. Am. Chem. Soc.*, **97**, 1662 (1975), and references therein.
- (7) B. B. Graves, *Anal. Chem.*, **44**, 993 (1972), and references therein.
- (8) M. C. Wall and K. J. Laidler, *Arch. Biochem. Biophys.*, **43**, 299 (1953).
- (9) K. J. Laidler, "The Chemical Kinetics of Enzyme Action", Oxford Press, London, 1958, p. 292.
- (10) P. R. Moses, L. Wier, and R. W. Murray, *Anal. Chem.*, **47**, 1882 (1975).
- (11) B. F. Watkins, J. R. Behling, E. Kariv, and L. L. Miller, *J. Am. Chem. Soc.*, **97**, 3549 (1975).
- (12) N. R. Armstrong, A. V. C. Lin, M. Fujihira, and T. Kuwana, *Anal. Chem.*, **48**, 741 (1976).
- (13) R. F. Lane and A. T. Hubbard, *J. Phys. Chem.*, **77**, 1401 (1973).
- (14) C. B. Afinsen and H. A. Sheraga, *Adv. Protein Chem.*, **29**, 209 (1975).
- (15) I. V. Berezin, A. M. Kilbanor, and K. Martinek, *Russ. J. Phys. Chem.*, **49**, 1480 (1975).
- (16) The support of this research by the National Science Foundation is gratefully acknowledged.

K. S. V. Santhanam, Neil Jespersen, Allen J. Bard*

Department of Chemistry, The University of Texas at Austin
Austin, Texas 78712

Received July 30, 1976

Paramagnetic Organometallic and Dialkylamide Complexes of Trivalent Titanium, Vanadium, and Chromium Stabilized by Diketonate Ligands

Sir:

Organometallic complexes of the early transition metals¹ and, in particular, paramagnetic complexes are generally very reactive and unstable. Large, bulky ligands such as $-C(CH_3)_3$, $-CH_2Si(CH_3)_3$, and $-N[Si(CH_3)_3]_2$, however, have yielded

some very interesting and stable complexes. We are currently interested in preparing organometallic complexes of the early metals^{2,3} and sought new starting materials for these reactions. The most commonly used reagents are the insoluble polymeric anhydrous metal halides and their tetrahydrofuran derivatives, i.e., $TiCl_3(THF)_3$, but these materials often lead to undesirable products.⁴ We have now discovered a new series of compounds of trivalent titanium, vanadium, and chromium **1**, that are useful reagents for the syntheses of a variety of new and unusual paramagnetic, organometallic compounds.

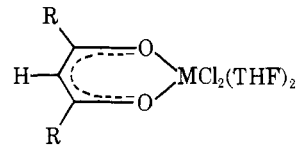

1

M = Ti, V, Cr

R = $-CH_3$, $-C_6H_5$, $-C(CH_3)_3$

The titanium and chromium derivatives are prepared directly from $MCl_3(THF)_3$ and 1 equiv of the appropriate 1,3-diketone in tetrahydrofuran. For example, a suspension of anhydrous $TiCl_3$ (35.0 g) in 500 ml of dry THF was refluxed under nitrogen for 2 h, and dipivaloylmethane (DPM-H) (41.8 g) was added dropwise. The solution was stirred magnetically for 1 h, cooled, and filtered and the solvent was removed to give red-purple crystals that were washed from the flask with pentane and dried. The yield of $(DPM)TiCl_2(THF)_2$ was 97.0 g (96%). The analogous vanadium complexes were prepared in only low yield by this procedure; however, good yields may be obtained by the addition of a THF solution of the sodium or potassium salt of the diketone (prepared in situ) to a refluxing solution of $VCl_3(THF)_3$ in tetrahydrofuran. The diketone complexes (diket) $VCl_2(THF)_2$ were isolated as brown or yellow-green air-sensitive crystalline solids.

The magnetic moments of **1** were measured in solution by the Evans method⁵ and were in the range 1.7–1.9, 2.6–2.7, and 3.7–3.9 μ_B for the titanium, vanadium, and chromium complexes, respectively. These values are in the range expected for octahedral d^1 , d^2 , and d^3 electronic configurations⁶ of trivalent Ti, V, and Cr.

The addition of 2 equiv of $Li-o-C_6H_4CH_2N(CH_3)_2$ to a solution of $(DPM)TiCl_2(THF)_2$ in ether under an inert atmosphere at room temperature gave a dark green solution containing a suspension of lithium chloride. From this solution **2** was isolated in ~70% yield as a dark green, very air-sensitive

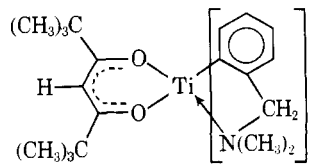

2

solid. It decomposes over a period of several days when stored under nitrogen at room temperature but may be stored for months at $-40^\circ C$ without any apparent decomposition. Its electronic spectrum is typical of octahedral d^1 complexes⁷ with an absorption band at 385 nm and a shoulder at 656 nm. The magnetic moment of 1.7 μ_B is also consistent with trivalent titanium. Hydrolysis of a benzene solution of **2** with D_2O gave $C_6H_4DCH_2N(CH_3)_2$, confirming the metalation of the benzylidene dimethylamine ligand. The vanadium analogue of **2** was synthesized in an analogous fashion and isolated as a dark maroon, air-sensitive crystalline solid. Unlike the titanium complex it may be stored under nitrogen at room temperature without decomposition. The magnetic moment (2.7 μ_B) was close to the spin only value of 2.83 μ_B .

Bradley and co-workers⁴ have studied the reactions of $\text{LiN}[\text{Si}(\text{CH}_3)_3]_2$ with a variety of transition metals and have prepared some interesting three-coordinate complexes. We have isolated novel four-coordinate derivatives of titanium and vanadium **3** from the reaction of 2 equiv of $\text{LiN}[\text{Si}(\text{CH}_3)_3]_2$

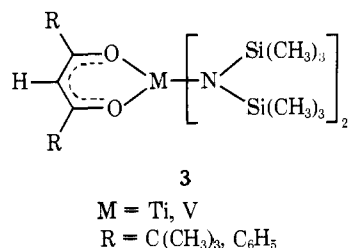

with the appropriate diketonate complex. They are air-sensitive, highly colored crystalline solids. The mass spectra of the dipivaloylmethanato derivatives exhibit parent ion peaks. The magnetic and spectral data are consistent with the proposed structure. Several reactions of $\text{LiN}[\text{Si}(\text{CH}_3)_3]_2$ with (diket)- $\text{CrCl}_2(\text{THF})_2$ gave brown to orange-red solutions but no products could be isolated in pure form.

We are currently examining further reactions and the chemistry of these novel diketonate stabilized organometallic and dialkylamide complexes.

References and Notes

- (1) R. R. Schrock and G. W. Parshall, *Chem. Rev.*, **1**, 243 (1976); P. J. Davidson, M. F. Lappert, and R. Pierce, *ibid.*, **1**, 219 (1976).
- (2) L. E. Manzer, *Inorg. Chem.*, **15**, 2567 (1976).
- (3) L. E. Manzer, *Inorg. Chem.*, submitted for publication.
- (4) E. C. Alyea, D. C. Bradley, and R. G. Copperthwaite, *J. Chem. Soc., Dalton Trans.*, 1580 (1972).
- (5) D. F. Evans, *J. Chem. Soc.*, 2003 (1959).
- (6) B. N. Figgis and J. Lewis, *Prog. Inorg. Chem.*, **6**, 37 (1967).
- (7) A. B. P. Lever, "Inorganic Electronic Spectroscopy", Elsevier, New York, N.Y., 1968.

Leo E. Manzer

Contribution No. 2431, Central Research and Development
Department, Experimental Station
E. I. du Pont de Nemours and Company
Wilmington, Delaware 19898

Received September 17, 1976

Exciplex Quenching. A Frontier Molecular Orbital Rationale

Sir:

The quenching of singlet exciplexes by electron donors or acceptors¹ has been highly useful in mechanistic dissection of photocycloadditions reactions.² We now report a simple frontier molecular orbital (FMO) analysis of data for quenching of a large number of exciplexes by electron donors from which order of magnitude predictions of quenching rates (k_Q) can be made for any singlet exciplex.

Four new exciplex orbitals χ_1 , χ_2 , χ_3 , and χ_4 are derived from the $\text{HOMO}_D\text{-HOMO}_A$ and $\text{LUMO}_D\text{-LUMO}_A$ interactions³ when an excited donor, D^* , forms an exciplex with a ground-state acceptor, A (Figure 1). We suggest that perturbation of χ_2 by the HOMO of the quenching donor, D_Q , adequately describes the quenching. Such perturbations will be maximal when HOMO_{D_Q} lies close to χ_2 in energy and should result in actual electron transfer when it is exothermic. Donor quenching efficiencies for any exciplex can, in principle, be estimated from the $\text{HOMO}_{D_Q}\text{-}\chi_2$ energy gap, $\Delta E_Q'$. Since the energy of χ_2 is presently unobtainable, we assume that the energy of HOMO_D approximates to that of χ_2 and calculate an alternative parameter $\Delta E_Q[\text{Ip}(D) - \text{Ip}(D_Q)]^4$. A plot of

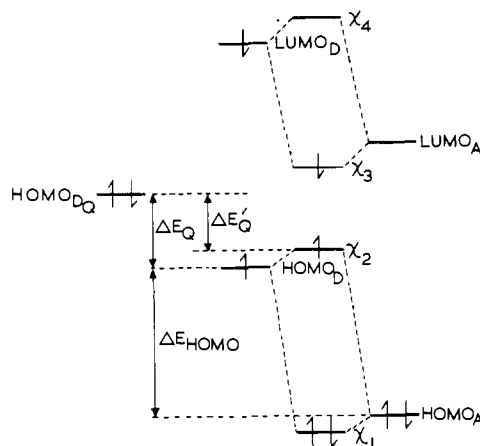

Figure 1. FMO picture of exciplex formation and quenching by an electron donor.

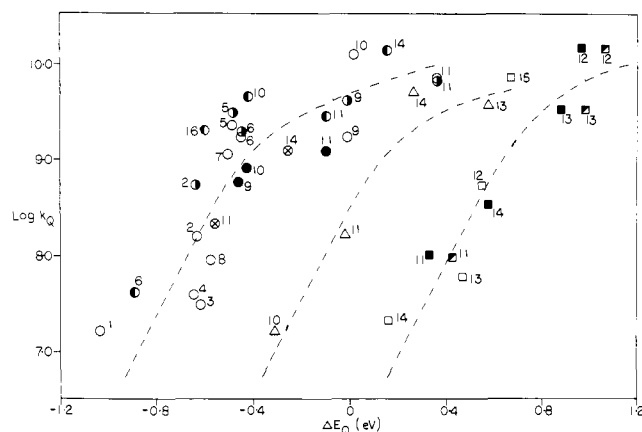

Figure 2. $\log k_Q$ vs. ΔE_Q for quenching of exciplexes by electron donors. Exciplexes are: anthracene-FN (\bullet), pyrene-FN (\circ), P-F (\odot), P-FN (\circ), 9CNP-PhNEt₂ (\otimes), 3,6MeO₂P-9CNP (Δ), 9CNP-*t*-An (\blacksquare), 9CNP-*p*-BA (\blacksquare), and the pyrene excimer (\square). Quenchers are: (1) 2-methyl-but-2-ene, (2) ethyl vinyl ether, (3) styrene, (4) α -methylstyrene, (5) dihydropyran, (6) 2,3-dimethyl-but-2-ene, (7) β -methylstyrene, (8) anisole, (9) phenanthrene, (10) *p*-methoxy- β -methylstyrene (*t*-An), (11) triethylamine, (12) triphenylamine, (13) diethylaniline, (14) diphenylamine, (15) *N,N'*-tetramethyl-*p*-phenylenediamine, (16) diethylamine.

Table I

Exciplex	λ_{\max}^c (nm)	τ^e (ns)	ΔE_{HOMO}^f (eV)
Anthracene-FN	570 ^d	7.5	3.74
Pyrene-FN	515	9.6	3.74
P-F ^a	480	1.4	3.37
P-FN	460	12.5	3.27
9CNP-PhNEt ₂	489	16.8	1.46
3,6MeO ₂ P-9CNP	444	8.0	1.04
9CNP- <i>t</i> -An	430	7.9	0.73
9CNP- <i>p</i> -BA ^b	438	15.8	0.63
Pyrene excimer	478	16.4 ^g	0.00

^a Dimethylfumarate. ^b *p*-Butenylanisole. ^c In benzene. Corrected, ± 3 nm. ^d ± 10 nm. Very weak emission. ^e Air-saturated benzene. Determined either by nanosecond flash spectroscopy or from the effect of air saturation on the exciplex fluorescence intensity. ^f $\Delta E_{\text{HOMO}} = \text{Ip}(A) - \text{Ip}(D)$. ^g At [pyrene] = 5.2×10^{-2} M.

$\log k_Q$ vs. ΔE_Q for eight exciplexes (Table I), the pyrene excimer, and 16 different quenchers is given in Figure 2. Although the data points show considerable scatter, not surprising considering the wide structural variation in donors and exciplexes, several trends are apparent: (1) Three lines adequately encompass all the data. (2) Each line shows the pronounced